



standards

Model document of an **Amendment**

“Rice model amendment”

Model document of an **Amendment**

The model document shown on the following pages demonstrates the application of certain instructions contained in the *ISO/IEC Directives, Part 2, 2016, Principles and rules for the structure and drafting of ISO and IEC documents*. It is not a real Amendment. The text has no technical significance.

It is intended as a complement to the model document of an International Standard (“Rice model”) (see www.iso.org/iso/model_document-rice_model.pdf) and constitutes a fictitious Amendment to the fictitious International Standard (ISO 17031-1:2016) used in the Rice model.

Although this model document is based on an Amendment from one particular Technical Committee, it is applicable to all Technical Committees.

The right-hand pages show the model Amendment; explanations and information about the content are shown on the left-hand pages.

An Amendment is used together with the document that it amends (see **ISO/IEC Directives, Part 1, 2016, 2.10**). It shall comprise only changes to the document it amends. When drafting an Amendment, be sure to compare with the source document.

It is only possible to publish an Amendment to a published document.

The ISO/IEC Directives, Part 1, 2016, 2.10.4, state: “*No more than 2 separate documents in the form of technical corrigenda or amendments shall be published modifying a current International Standard. The development of a third such document shall result in publication of a new edition of the International Standard.*”

Give the Title of the document to which the Amendment applies.

It is also useful to give the Amendment a title.

Second edition
2016-05-01

AMENDMENT 1
2017-02

**Cereals and pulses — Specification
and test methods —**

**Part 1:
Rice**

**AMENDMENT 1: Mass fraction of
extraneous matter, milled rice (non-
glutinous), sample dividers and
recommendations relating to storage and
transport conditions**

Céréales et légumineuses — Spécification et méthodes d'essai —

Partie 1: Riz

*AMENDEMENT 1: Fraction massique de matière étrangère, riz usiné
(non gluant), diviseurs d'échantillon et recommandations relatives
aux conditions d'entreposage et de transport*



Reference number
ISO 17301-1:2016/Amd.1:2017(E)

© ISO 2017



COPYRIGHT PROTECTED DOCUMENT

© ISO 2017, Published in Switzerland

All rights reserved. Unless otherwise specified, no part of this publication may be reproduced or utilized otherwise in any form or by any means, electronic or mechanical, including photocopying, or posting on the internet or an intranet, without prior written permission. Permission can be requested from either ISO at the address below or ISO's member body in the country of the requester.

ISO copyright office
Ch. de Blandonnet 8 • CP 401
CH-1214 Vernier, Geneva, Switzerland
Tel. +41 22 749 01 11
Fax +41 22 749 09 47
copyright@iso.org
www.iso.org

A Foreword shall appear in each document. The generic text is shown here. It does not contain requirements, recommendations or permissions.

The generic text may be revised periodically by ISO. In this case, the Foreword was updated between the publication of the fictitious International Standard and this fictitious Amendment. The fifth paragraph now includes an explanation of the voluntary nature of standards as well as other supplementary information.

In addition to the generic text, the designation and name of the technical committee (and subcommittee, if applicable) that prepared the document are given, together with an indication of any other international organization that has contributed to the preparation of the document, if appropriate.

Foreword

ISO (the International Organization for Standardization) is a worldwide federation of national standards bodies (ISO member bodies). The work of preparing International Standards is normally carried out through ISO technical committees. Each member body interested in a subject for which a technical committee has been established has the right to be represented on that committee. International organizations, governmental and non-governmental, in liaison with ISO, also take part in the work. ISO collaborates closely with the International Electrotechnical Commission (IEC) on all matters of electrotechnical standardization.

The procedures used to develop this document and those intended for its further maintenance are described in the ISO/IEC Directives, Part 1. In particular the different approval criteria needed for the different types of ISO documents should be noted. This document was drafted in accordance with the editorial rules of the ISO/IEC Directives, Part 2 (see www.iso.org/directives).

Attention is drawn to the possibility that some of the elements of this document may be the subject of patent rights. ISO shall not be held responsible for identifying any or all such patent rights. Details of any patent rights identified during the development of the document will be in the Introduction and/or on the ISO list of patent declarations received (see www.iso.org/patents).

Any trade name used in this document is information given for the convenience of users and does not constitute an endorsement.

For an explanation on the voluntary nature of standards, the meaning of ISO specific terms and expressions related to conformity assessment, as well as information about ISO's adherence to the World Trade Organization (WTO) principles in the Technical Barriers to Trade (TBT) see the following URL: www.iso.org/iso/foreword.html.

This document was prepared by Technical Committee ISO/TC 34, *Food products*, Subcommittee SC 4, *Cereals and pulses*.

A list of all parts in the ISO 17301 series can be found on the ISO website.

A Scope is not included in an Amendment. The following elements are also not included:

- ▶ Table of contents
- ▶ Introduction

The element that is to be amended from the original document is clearly specified (e.g. number of clause, subclause, figure, table, formula), followed by a clear indication of what is being amended (e.g. by using the verbs “replace”, “delete”, “add”).

In this case, the information on the patented items, which was in the Introduction of the original document, has been deleted because the patented item has been removed (see Figure A.1).

When preparing an Amendment, check the validity of the references listed in the Normative references clause and the Bibliography. Any references that are out of date shall be updated.

In this case, the dated reference in the Normative references clause has been updated to correspond to the updated reference in Clause 8.

Cereals and pulses — Specification and test methods —

Part 1: Rice

AMENDMENT 1: Mass fraction of extraneous matter, milled rice (non-glutinous), sample dividers and recommendations relating to storage and transport conditions

Introduction

Delete the fourth to seventh paragraphs.

Normative references

Replace the reference to ISO 16634:— (including the footnote) with the following:

ISO 16634-2:2016, *Food products — Determination of the total nitrogen content by combustion according to the Dumas principle and calculation of the crude protein content — Part 2: Cereals, pulses and milled cereal products*

Renumber subsequent footnotes.

4.1, second paragraph

Replace the paragraph with the following:

There shall be a procedure to identify the maximum permissible levels for additives and pesticide residues and other contaminants in the country of destination.

4.2.1

Designate the existing NOTE as NOTE 1 and add the following new NOTE:

NOTE 2 For certain destinations, no differentiation is made between the organic and inorganic mass fractions of extraneous matter.

Information that has become outdated since the publication of the document shall be updated.

When a new annex is added to a document, a reference needs to be made to that new annex in the body of the document, as shown in the modification to Clause 8.

4.2.2, Table 1

In the column “in milled rice (non-glutinous)”, replace the value “0,3” for “Paddy” with the value “0,5”.

6.3, first paragraph

Replace the reference “ISO 16634:—, Clause 9” with “ISO 16634-2:2016, Clause 9”.

Clause 8

Add the following paragraph at the end of the clause:

Annex E gives recommendations relating to storage and transport conditions.

Clause 9

Replace the text with the following:

The marking on the packages shall clearly identify the type of rice.

A.2.1

Replace the text with the following:

A.2.1 Sample divider, consisting of a conical sample divider or multiple-slot sample divider with a distribution system, e.g. conical (Boerner-type) divider such as that shown in Figure A.1 or multiple-slot (riffle-type) divider such as that shown in Figure A.2.

The original Figure A.1 illustrated a patented item. The new Figures A.1 and A.2 do not illustrate patented items and are therefore preferable.

Where possible, non-patented items shall be specified in preference to patented items (see **ISO/IEC Directives, Part 1, 2016, 2.14**).

Figure A.1

Replace Figure A.1 with the following two figures:

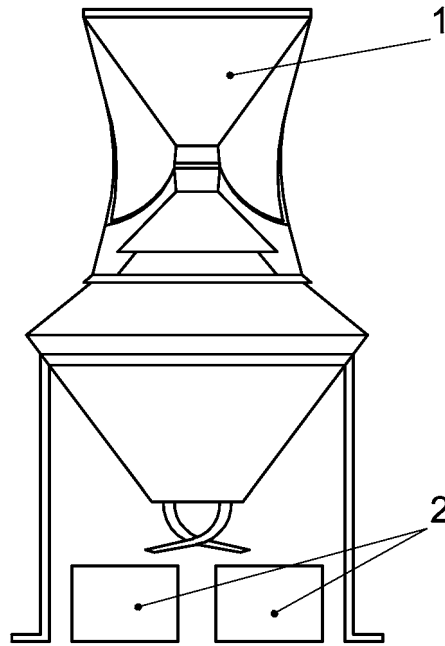

Key

- 1 funnel
- 2 collection boxes

Figure A.1 — Conical (Boerner-type) divider

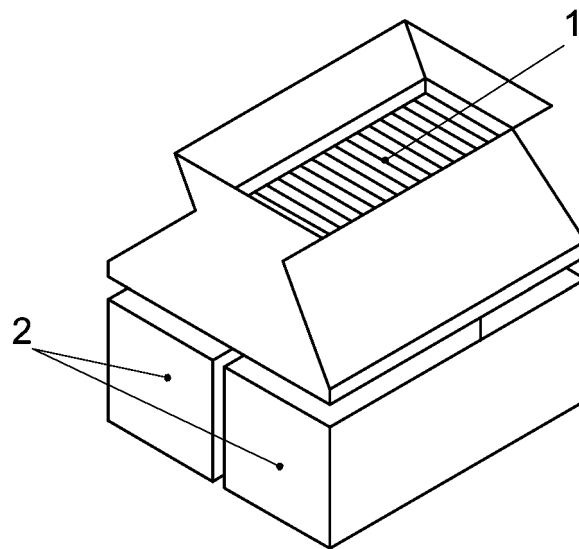

Key

- 1 slots
- 2 collection boxes

Figure A.2 — Multiple-slot (riffle-type) divider with two collection boxes

When a new annex is added to a document, a reference needs to be made to that new annex in the body of the document, as shown in the modification to Clause 8.

Annex E

Add the following annex after Annex D, before the Bibliography.

Annex E

(informative)

Recommendations relating to storage and storage and transport conditions

Containers of rice should be stored in covered premises, well protected from the sun, rain and excessive heat.

The storeroom should be dry, free from unpleasant odours and protected against entry of insects and other vermin. Ventilation should be adjusted in such a way as to give good ventilation during dry weather and to be fully closed under damp conditions. Suitable provisions should be made for fumigation of storerooms.

Containers should be handled and transported in such a way that they are protected from the rain, sun or other sources of excessive heat, unpleasant odours and any other contamination (especially in the holds of ships).

About ISO

ISO (International Organization for Standardization) is an independent, non-governmental international organization with a membership of 161* national standards bodies. Through its members, it brings together experts to share knowledge and develop voluntary, consensus-based, market-relevant International Standards that support innovation and provide solutions to global challenges.

ISO has published more than 21 400* International Standards and related documents covering almost every industry, from technology to food safety, to agriculture and healthcare.

For more information, please visit www.iso.org.

*January 2017

International Organization for Standardization

ISO Central Secretariat
Chemin de Blandonnet 8
Case Postale 401
CH – 1214 Vernier, Geneva
Switzerland

iso.org

© ISO, 2017
All rights reserved
ISBN 978-92-67-10726-4

